

**NTB24033HN12 Non-Isolated DC-DC Converters**

Input 6V-36V, Output 12V/3.3A, Dual-in-line Package

**Contents**

Features ..... 1  
 Ordering Information..... 1  
 Outline Diagram ..... 2  
 Specifications ..... 2  
 Characteristic Curves..... 3  
 Design Considerations..... 5  
     Basic Connection..... 5  
     Recommended Layout..... 6  
     Input Voltage Range ..... 6  
     Remote Control ..... 6  
     Output Voltage Adjust..... 6  
     External Capacitance ..... 7  
     Over Temperature Protection (OTP)..... 7  
     Thermal Consideration ..... 7  
     Power Good..... 8  
 Delivery Package Information..... 8  
 Quality Statement ..... 8  
 Contact Information..... 8



**Features**

- ◆ *Package 33.0mm×25.4mm×11.0mm*
- ◆ *Wide Input Voltage(6Vdc~36Vdc)*
- ◆ *Negative Logic Control (low level or floating turn on)*
- ◆ *High Efficiency: 96% typ.:Input Voltage 12.0V, Load current:3.3A; 95% typ.: Input Voltage 24.0V, Load current:3.3A*
- ◆ *Short Circuit Protection,Auto Recovery*
- ◆ *Over Temperature Protection(OTP)*
- ◆ *Operating Temperature: -40 °C to +85 °C*
- ◆ *Max Load Current: 3.3A*
- ◆ *Application: Vehicle-mounted system, Telecommunication equipments, Industrial control, Electric power, battery powered equipment, etc.*

**Ordering Information**

See Contents for individual product ordering numbers.

Ordering No.	Description
NTB24033HP12	Positive logic
NTB24033HN12	Negative logic

**NTB24033HN12 Non-Isolated DC-DC Converters**

Input 6V-36V, Output 12V/3.3A, Dual-in-line Package

**Outline Diagram**

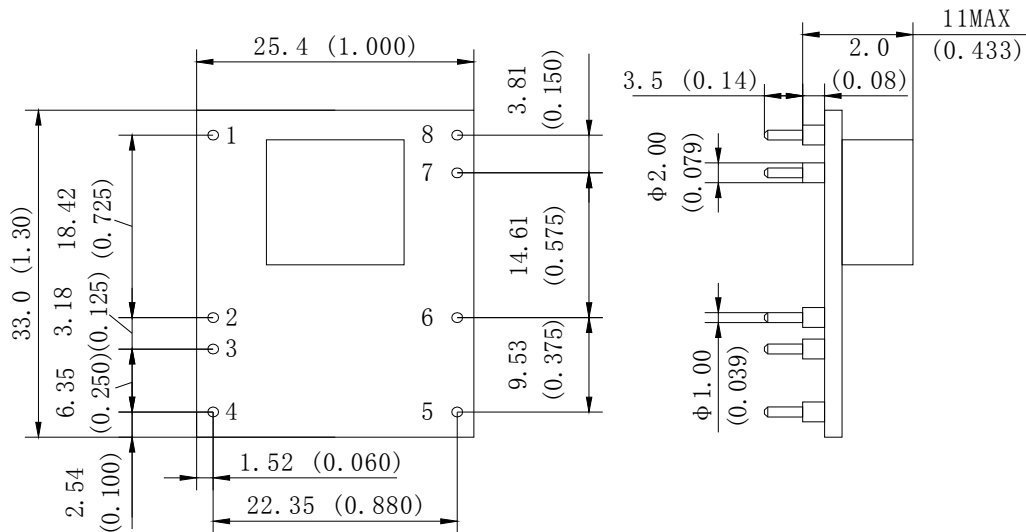

Pin	Symbol	Function	Pin	Symbol	Function
1	V <sub>in</sub>	Positive Input	5	PwrGood	Indicating Power OK
2,6	GND	Common Ground For Input And Output			
3	TRIM	Output Voltage Trim	7	V <sub>o</sub>	Positive output
4	CNT	Remote Control	8	RS	Remote Sense

**Pin:** copper with gold plating.  
**Notes:** all dimensions in mm(inches)  
**Tolerances:** X.X ± 0.5 (X.XX ± 0.02)      X.XX ± 0.25 (X.XXX ± 0.010)

**Specifications**

Unless otherwise specified, all values are given at: 25°C, standard atmosphere pressure, pure resistive load and basic connection.

Input	Symbol	Min	Typ	Max	Unit	Conditions	
Input Voltage	V <sub>in</sub>	6.0	12.0/24.0	36.0	V	—	
Negative Logic Control	Turn on	—	0	—	1	V	Refer to GND; Also turn on when CNT floating
	Turn off	—	2.5	—	10.0	V	Refer to GND
	Current	—	—	—	1	mA	CNT sink current when turn off
Positive Logic Control	Turn on	—	2.5	—	10.0	V	Refer to GND; Also turn on when CNT floating.
	Turn off	—	0	—	1	V	Refer to GND
	Current	—	—	—	1	mA	CNT source current when turn off
Under Voltage Threshold	V <sub>UVLO</sub>	4.5	—	5.5	V	—	
Maximum Input Voltage	—	—	—	50	V	I <sub>O</sub> =3.3A, Power up 1 minute without damage	
Oversvoltage Surge	—	—	—	60	V	I <sub>O</sub> =3.3A, Power up 50 milliseconds without damage	

Output	Symbol	Min	Typ	Max	Unit	Conditions
Output Voltage	V <sub>O</sub>	11.88	—	12.12	V	—
Output Current	I <sub>O,nom</sub>	0	—	3.3	A	—

## NTB24033HN12 Non-Isolated DC-DC Converters

Input 6V-36V, Output 12V/3.3A, Dual-in-line Package

Continue

Output	Symbol	Min	Typ	Max	Unit	Conditions
Line Regulation	$S_V$	—	—	±0.3	% $V_O$	$V_{in}=6V\sim 36V, I_O=3.3A$
Load Regulation	$S_I$	—	—	±0.5	% $V_O$	$V_{in,nom}, I_O=0\sim 3.3A$
Output Voltage Adjust Range	$V_{trim}$	10.8	—	13.2	V	$V_{in,nom}, P_O\leq 40W, I_O\leq 3.3A$
Current Limit Threshold	$I_{O,lim}$	3.63	—	—	A	—
Peak to Peak Ripple and Noise	$\Delta V_{pp}$	—	—	100	mV	20MHz bandwidth
Output Short-circuit Protection	cycle by cycle protected, auto-recovery					
Rise Time	$T_{rise}$	—	—	40	ms	$I_{O,nom}$ , pure resistive load
Start-up Delay Time	$T_{delay}$	—	—	20	ms	$I_{O,nom}$ , pure resistive load
Capacitive Load Range	$C_O$	0	—	1000	$\mu F$	—
Load Transient	Recovery Time	$t_{tr}$	—	200	$\mu s$	25%~50%~25% $I_{O,nom}$ or 50%~75%~50% $I_{O,nom}, 0.1A/\mu s$
	Voltage Deviation	$\Delta V_{tr}$	—	±4	% $V_O$	50%~100%~50% $I_{O,nom}, 2.5A/\mu s$

Output	Symbol	Min	Typ	Max	Unit	Conditions
Efficiency	$\eta$	94	96	—	%	$V_{in}=12V, I_O=3.3A$
		93	95	—	%	$V_{in}=24V, I_O=3.3A$
Switching Frequency	$f_s$	—	400	—	kHz	—
MTBF	—	$5\times 10^6$	—	—	h	BELLCORE TR-332
Operating Temperature	—	-40	—	+85	$^{\circ}C$	—
Storage Temperature	—	-55	—	+125	$^{\circ}C$	—
Relative Humidity	—	5	—	95	%	—
Temperature Coefficient	$S_T$	—	—	±0.02	%/ $^{\circ}C$	—
Over Temperature Protection Reference Point	$T_{ref}$	100	110	120	$^{\circ}C$	The specific test point for OTP: See application information section
Hand Soldering	Maximum soldering Temperature < 425 $^{\circ}C$ , and duration < 5s					
Wave Soldering	Maximum soldering Temperature < 255 $^{\circ}C$ , and duration < 10s					
Weight	—	—	10	—	g	—

### Characteristic Curves

Load Transient Response

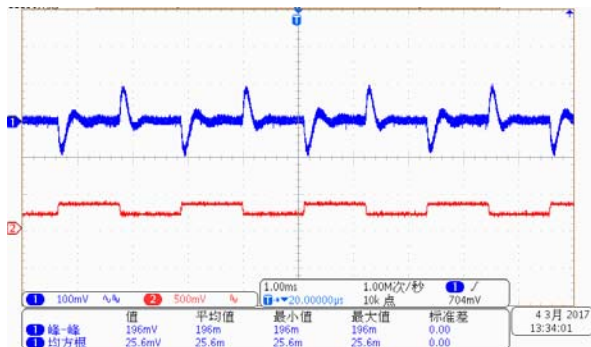

Load change: 25%~50%  
~25%  $I_{O,nom}$ , 0.1A/ $\mu s$   
 $V_{in}=12Vdc$   
Trace1: 0.1V/div  
Trace2: 3A/div  
Time scale: 1ms/div

Load Transient Response

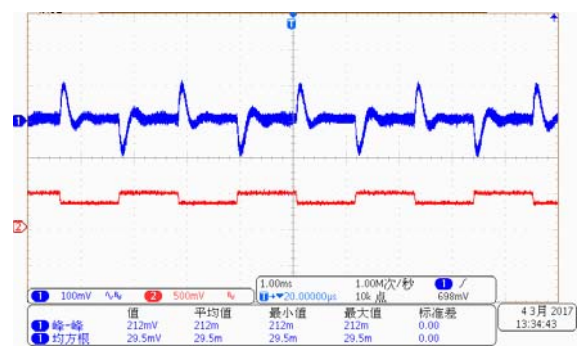

Load change: 50%~75%  
~50%  $I_{O,nom}$ , 0.1A/ $\mu s$   
 $V_{in}=12Vdc$   
Trace1: 0.1V/div  
Trace2: 3A/div  
Time scale: 1ms/div

**NTB24033HN12 Non-Isolated DC-DC Converters**

Input 6V-36V, Output 12V/3.3A, Dual-in-line Package

**Load Transient Response**

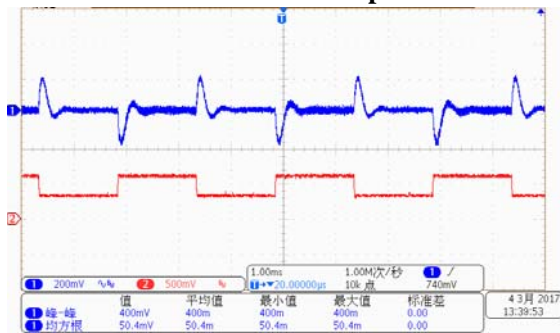

Load change: 50%~100% Trace1: 0.2V/div  
 ~50% Io,nom, 2.5A/ $\mu$ s Trace2: 3A/div  
 Vin=12Vdc Time scale: 1ms/div

**Load Transient Response**

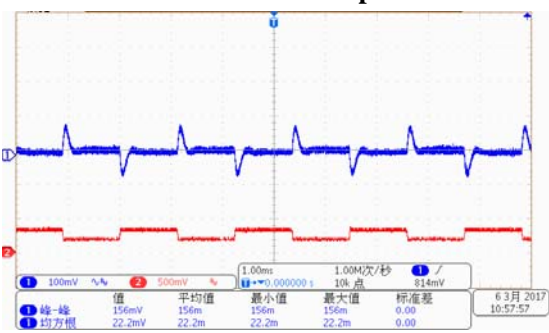

Load change: 25%~50% Trace1: 0.1V/div  
 ~25% Io,nom, 0.1A/ $\mu$ s Trace2: 3A/div  
 Vin=24Vdc Time scale: 1ms/div

**Load Transient Response**

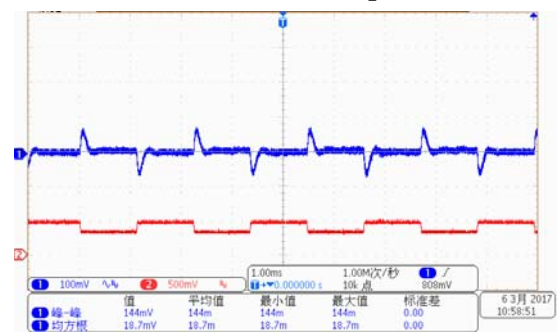

Load change: 50%~75% Trace1: 0.1V/div  
 ~50% Io,nom, 0.1A/ $\mu$ s Trace2: 3A/div  
 Vin=24Vdc Time scale: 1ms/div

**Load Transient Response**

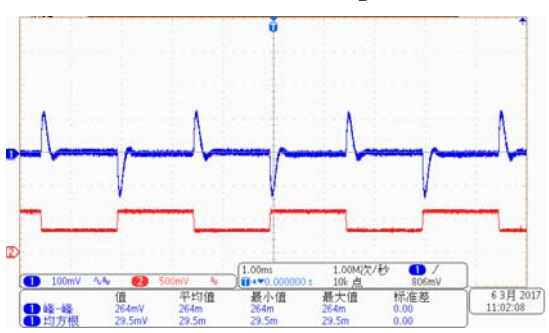

Load change: 50%~100% Trace1: 0.1V/div  
 ~50% Io,nom, 2.5A/ $\mu$ s Trace2: 3A/div  
 Vin=24Vdc Time scale: 1ms/div

**Output Ripple**

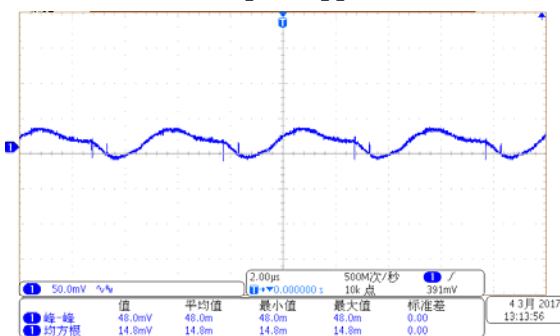

Vin=12Vdc, Io=3.3A

**Output Ripple**

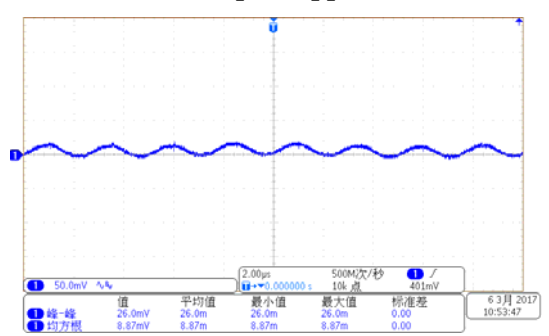

Vin=24Vdc, Io=3.3A

**Rise Time**

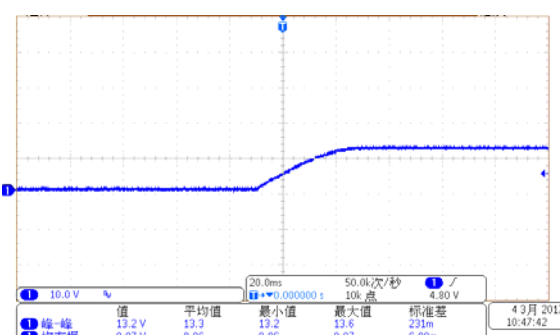

Vin=12Vdc, Io=3.3A

**Rise Time**

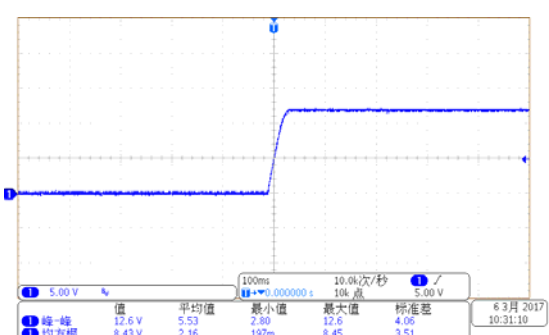

Vin=24Vdc, Io=3.3A

**NTB24033HN12 Non-Isolated DC-DC Converters**

Input 6V-36V, Output 12V/3.3A, Dual-in-line Package

Turn-off

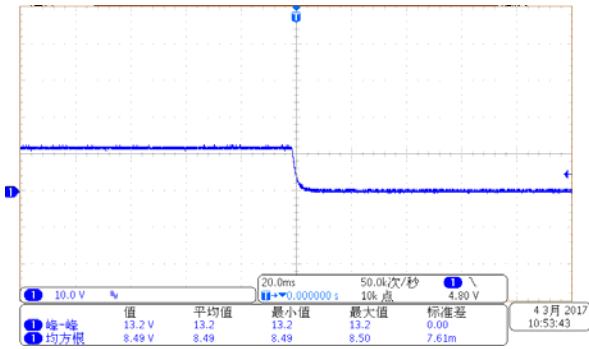

Vin=12Vdc, Io=3.3A

Efficiency

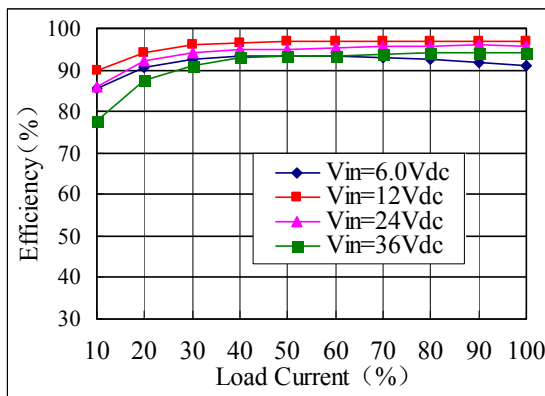

Turn-off

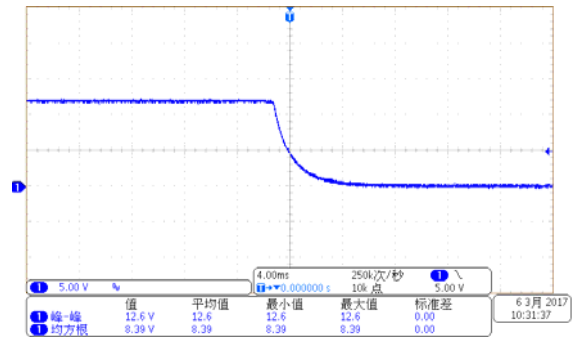

Vin=24Vdc, Io=3.3A

Derating(Vin=24Vdc)

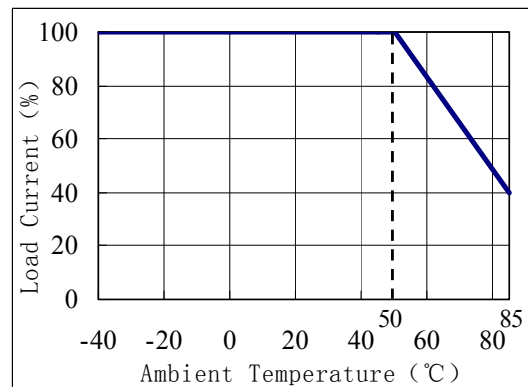

**Design Considerations**

**Basic Connection**

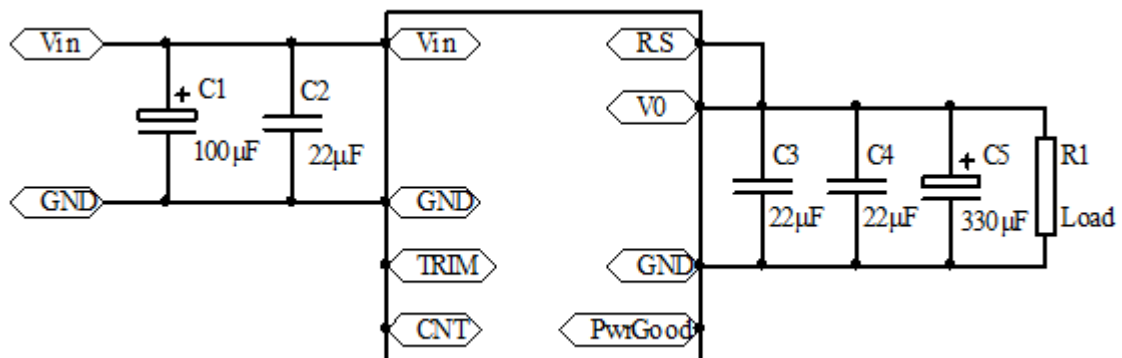

Notes: Please see the application information followed for the further information.

**NTB24033HN12 Non-Isolated DC-DC Converters**

Input 6V-36V, Output 12V/3.3A, Dual-in-line Package

**Recommended Layout**

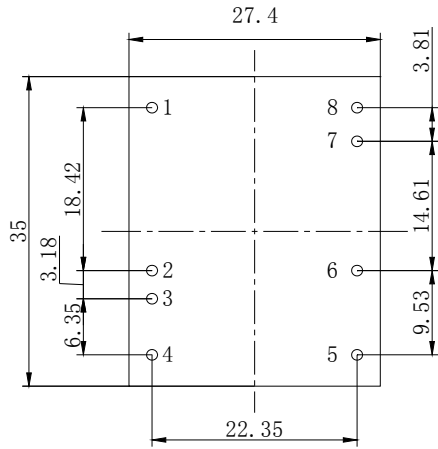

NO.	Recommendation & Notes
Pad Design	1-8 Pad holes : 1.5mm, pad diameter including hole : 2.5mm in X axis and $\leq 2.0\text{mm}$ in Y axis
Electric	The common ground planes should be placed under of the converter separately. Avoid routing sensitive signal or high disturbance AC signal under the converter.

**Input Voltage Range**

The Input voltage range of the regulator is 6V to 36V. The input impedance of the regulator looks like a negative resistor, which can interact with the reactance of the power bus (including any filter elements that have been added to the input of the regulator), causes an unstable condition. The source impedance of the regulator should be as low as possible to ensure stable operation. The input filter capacitors should be paralleled equidistantly and connected as close as possible to the input pins.

**Remote Control**

Remote control can be offered by setting right control voltage level (or floating) to CNT pin. NTB24033HN12 is provided with negative logic remote control. The circuit diagram is shown as “Remote Control Circuit Diagram”.

When the level is less than 1.0V or floating, the converter will be on; When the level is higher than 2.5V, the converter will be off.

NTB24033HP12 is provided with positive logic remote control. It has the same characteristic as NTB24033HN12, except control logic. When the level is less than 1.0V, the converter will be off; When the level is higher than 2.5V or floating, the converter will be on.

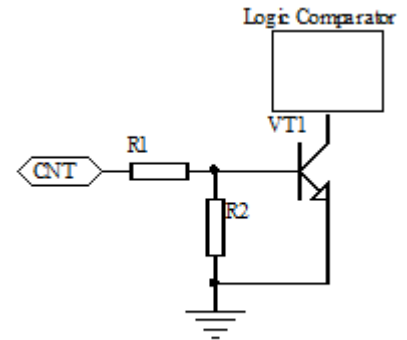

Remote Control Circuit Diagram

**Output Voltage Adjust**

The converters have an Output Voltage adjust pin (Trim). This pin can be used to adjust the output voltage above or below Output voltage initial setting. The maximum value of the trimmed up is 10%. The output power can not exceed 40W at increased output voltages, and the output current can not exceed 3.3A. When the trim pins are not used, they should be floated.

External circuit is connected as the figure shown, the resistance is calculated as the formula below, please note that the formula will be invalid when  $R_{Trim-up}$ ,  $R_{Trim-down}$  are used simultaneously, users adjust the value based on the resistance applied.

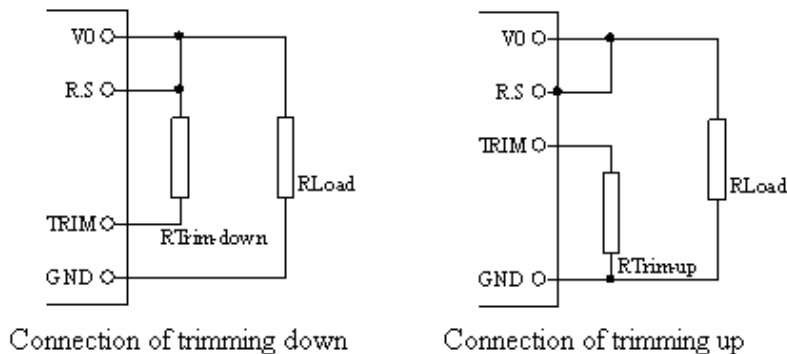

**NTB24033HN12 Non-Isolated DC-DC Converters**

Input 6V-36V, Output 12V/3.3A, Dual-in-line Package

Resistance for trimming up:  $R_{Trim-up} = \left( \frac{21.12}{\Delta V} - 15 \right) (k\Omega)$

Resistance for trimming down:  $R_{Trim-down} = \left( \frac{(V_o - \Delta V - 0.8) \times 26.4}{\Delta V} - 15 \right) (k\Omega)$

$R_{Trim-up}$ 、 $R_{Trim-down}$  :Resistance for trimming up or down, Unit:kΩ;

$\Delta V_o$ : Change rate, divide output voltage12V by rated output voltage;

For example:trimmed down voltage to 10.8V, then  $\Delta V = 12 - 10.8 = 1.2V$  ;

Resistance for trimming down:  $R_{Trim-down} = \left( \frac{(12 - 1.2 - 0.8) \times 26.4}{1.2} - 15 \right) = 205 (k\Omega)$ .

**External Capacitance**

Unless special purposes (i.e. prolonging hold-up time, input impedance matching), the recommended input capacitance range is 100μF to 470μF, which not only provide a stable operation, and reduce the cost, but also lessen the inrush current when the power supplies. In order to get less output ripple,input and output capacitance should as close as possible to pins.

When larger capacitance is required, a circuit of suppressing the inrush current is recommended when the regulator start-up and a discharge circuit is recommended when the output dropped, ensuring the reliability and safety of other equipments in the system.

**Over Temperature Protection (OTP)**

The over temperature protection feature is used to protect the converter. If the PCB temperature(reference point A and B,see the figure below)exceeds the threshold of 110°C, the converter will shut down.

The converter will stop until safe operating temperature is restored. Hysteresis temperature between OTP trig point and restart is approx 10°C. Time between OTP and restart is dependent on cooling of the regulator and radiation to the surrounding environment. If the surrounding environment does not change, restart will work cycle by cycle.

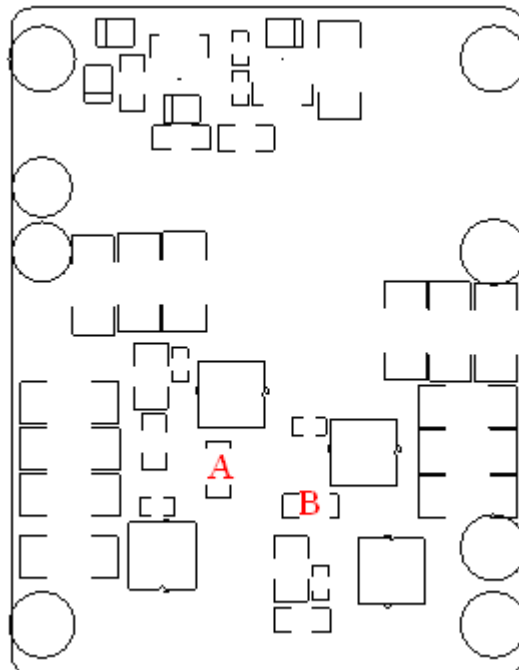

The Location Of Temperature Sensor A And B

**Thermal Consideration**

The regulators are designed to operate between -40°C~85°C, and sufficient cooling must be provided to ensure

**NTB24033HN12 Non-Isolated DC-DC Converters****Input 6V-36V, Output 12V/3.3A, Dual-in-line Package**

---

reliable operation. In order to the reliability ,the power should work according to derating curve under no airflow , and make sure the highest heating components (the inductor) is apart from the other parts more than 1mm.

**Power Good**

The module provides a Power Good (PwrGood) signal to indicate that the output voltage is with in the regulation limits of the power module. The PwrGood signal will be de-asserted to a low state if any condition such as over-temperature,over-current occurs that would result in the output voltage going  $\pm 10\%$  outside the set-point value. The PwrGood terminal is internally pulled-up and provides a voltage of 5.5V, when asserted, thus eliminating the need for an external source and pull-up resistor.

**Delivery Package Information**

Package material is multiple wall corrugated ,internal material is anti-static foam, it's surface resistance is from  $10^5 \Omega$  to  $10^{12} \Omega$ . Tray capacity:  $3 \times 30 = 90$  PCS/box, Tray weight: 1.0kg; Carton capacity:  $4 \times 90 = 360$  PCS, Carton weight: 4.0kg.

**Quality Statement**

The converters are manufactured in accordance with ISO 9001 system requirements, in compliant with YD/T1376-2005, and are monitored 100% by auto-testing system, 100% burn in. The warranty for the converters is 5-year.

**Contact Information**

*Anhui Hesion Trading Co., Ltd.  
& Beijing Yihongtai Technology Dev. Co., Ltd.*

TEL: +86-551-65369069, 65369067

Email: [alecz@ahhesion.com](mailto:alecz@ahhesion.com)

Backup: [alecz@126.com](mailto:alecz@126.com)

[www.ahhesionpower.com](http://www.ahhesionpower.com)