

**ZDE20A-24BS5B DC-DC Converters**

Input 9V-36V, Output 5V/20A, Industry Standard Eighth Brick

**Contents**

Features..... 1  
 Ordering Information..... 1  
 Outline Diagram ..... 2  
 Specification ..... 3  
 Characteristic Curves..... 4  
 Design Considerations..... 5  
     Basic Connection..... 5  
     Recommended Layout..... 6  
     Input Voltage Range..... 6  
     Remote Control..... 6  
     External Capacitance ..... 7  
     Output Voltage Adjust..... 7  
     Remote Sense ..... 8  
     Over Temperature Protection..... 8  
     Thermal Consideration ..... 8  
     Output Over Voltage Protection..... 8  
     Safety Consideration..... 9  
     Series and Parallel Operation..... 9  
     ESD Control ..... 9  
 Quality Statement ..... 9  
 Contact Information..... 9



*Converters ZDE20A-24BS5B*

**Features**

- ◆ Eighth Brick 58.4mm×22.8mm×10.0mm, no heatsink, 58.4mm×22.8mm×12.7mm, including heat sink
- ◆ Input Under Voltage Protection (6.0 to 8.9Vdc Turn off)
- ◆ Positive Logic Control (3.5V to 15V or floating Turn on)
- ◆ Output Over Voltage Protection (6V to 7V) ,
- ◆ Output Over Current Protection
- ◆ Output Short-circuit Protection, automatic recovery
- ◆ High Efficiency up to 92% (24V, full load)
- ◆ 1500Vdc Isolation Voltage
- ◆ Operation Ambient Temperature -40 °C to +85 °C
- ◆ 120 °C Typ. Over Temperature Protection
- ◆ Applications: Telecom& Datacom ,Industry control, Rail transit and Railway etc.

**Ordering Information**

See Contents for individual product ordering numbers.

Suffix	Description	Ordering No.
--	Positive Logic Control: 3.5V~15V or floating, turn on; 0V~1.5V, turn off	ZDE20A-24BS5
P	Negative Logic Control	ZDE20A-24BS5P
B	Equipped with metal baseplate. A heatsink can be installed on the baseplate.	ZDE20A-24BS5B
PB	Negative Logic Control. Equipped with metal baseplate. A heatsink can be installed on the baseplate.	ZDE20A-24BS5PB

**ZDE20A-24BS5B DC-DC Converters**

Input 9V-36V, Output 5V/20A, Industry Standard Eighth Brick

**Outline Diagram**

Outline Diagram without Baseplate (without suffix B)

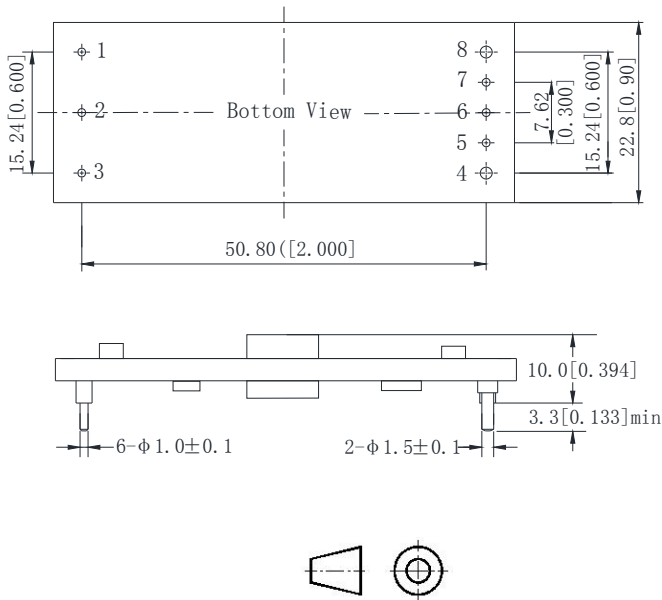

Outline Diagram with Baseplate (with suffix B)

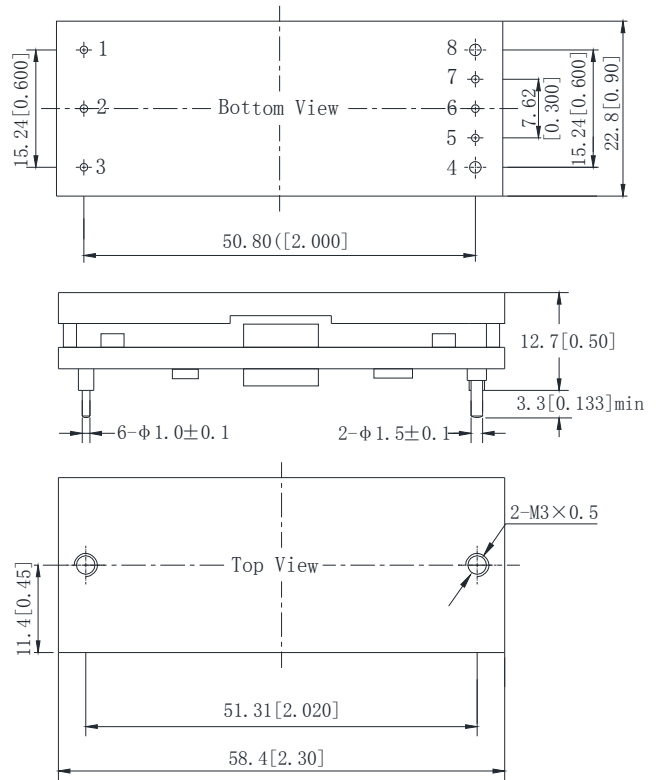

Pin	Symbol	Function
1	-Vin	Negative Input
2	Cnt	Remote Control, turn on/off the converter. Output voltage on when Cnt floating or high level applied.
3	+Vin	Positive Input
4	+V <sub>O</sub>	Positive Output
5	+S	Positive Remote Sense, connected to +V <sub>O</sub> pin when not in use.
6	Trim	Output Voltage Trim, voltage be trimmed up or down by applying external resistor connected to +S or -S output
7	-S	Negative Remote Sense, connected to -V <sub>O</sub> pin if not used.
8	-V <sub>O</sub>	Negative Output

Case Material: Multilayer PCB; Pin: Copper alloy with gold plating;

Baseplate Material: Aluminum

Notes: All dimensions in mm(inches)

Tolerances: X.X±0.5 (X.XX±0.02) X.XX±0.25 (X.XXX±0.010)

**ZDE20A-24BS5B DC-DC Converters**

Input 9V-36V, Output 5V/20A, Industry Standard Eighth Brick

**Specification**

Unless otherwise specified, all values are given at: 25°C, one standard atmosphere pressure, pure resistive load and basic connection.

Input		Symbol	Min	Typ	Max	Unit	Conditions
Input Voltage		$V_{in}$	9	24	36	Vdc	—
Input Current		$I_{in}$	—	—	14	A	$V_{in}=9Vdc, I_O=20A$
Negative Logic Control	On	—	3.5	—	15	Vdc	Refer to $-V_{in}$ , Turn on when Cnt floating.
	Current	—	—	1.0	—	mA	Cnt source current when turn on
	Off	—	0	—	1.2	Vdc	Refer to $-V_{in}$ ; Turn off when Cnt floating.
	Current	—	—	1.0	—	mA	Cnt output current when turn off
Start-up Delay Time		$T_{delay}$	—	10	—	ms	—
Under Voltage Threshold		$V_{UVLO}$	6.0	—	8.9	Vdc	50% load test
Under Voltage Protection Hysteresis		$\Delta V_{UVLO}$	—	1	—	Vdc	—

Output		Symbol	Min	Typ	Max	Unit	Conditions
Output Voltage		$V_O$	4.90	5.00	5.10	Vdc	—
Output Current		$I_{O,nom}$	—	20	—	A	—
Output Voltage Adjust Range		$V_{trim}$	4.5	—	5.5	Vdc	$I_O \leq 20A \quad P_o \leq 100W$
Line Regulation		$S_V$	—	—	$\pm 0.2$	% $V_O$	$V_{in}: 9 \sim 36Vdc, I_O=20A$
Load Regulation		$S_I$	—	—	$\pm 0.5$	% $V_O$	$V_{in}=24Vdc, I_O: 0A \sim 20A$
Output Over Voltage Protection Set Point		$V_{ov,set}$	6.0	—	7.0	Vdc	$V_{in}=24Vdc$
Output Over Current Protection Range		$I_{O,lim}$	21	—	38	A	$V_{in}=24Vdc$
Output Short-circuit Protection		automatic recovery					
Peak to Peak Ripple and Noise		$\Delta V_{pp}$	—	—	100	mV	$V_{in}=24Vdc, I_{O,nom}, 20MHz$ bandwidth, a 10 $\mu F$ Tantalum capacitor and a 1 $\mu F$ ceramic capacitor applied at output
Rise Time		$T_{rise}$	—	5	—	ms	$V_{in}=24V, I_{O,nom},$ pure resistive load
Output Overshoot		$V_{TO}$	0	—	0.5	Vdc	$V_{in}=24V, I_{O,nom},$ pure resistive load
Capacitive Load		$C_O$	0	—	2200	$\mu F$	pure resistive load
Remote Sense Compensation Range		$V_{sense}$	0	—	0.5	V	+S and -S twisted Pair, length is less than 20cm

General		Symbol	Min	Typ	Max	Unit	Conditions
Load Transient	Recovery Time	$\Delta V_{tr}$	—	$\pm 250$	—	mV	25%~50%~25% $I_{O,nom}$ or 50%~75%~50% $I_{O,nom}$ ; 0.1A/ $\mu s$
	Voltage Deviation	$t_{tr}$	—	1500	—	$\mu s$	
Efficiency		$\eta$	90	92	—	%	$V_{in}=24Vdc, I_{O,nom}$
Switching Frequency		$f_s$	—	230	—	kHz	—
Isolation Resistance		$R_{iso}$	50	—	—	M $\Omega$	—

**ZDE20A-24BS5B DC-DC Converters**

Input 9V-36V, Output 5V/20A, Industry Standard Eighth Brick

**Continue**

General	Symbol	Min	Typ	Max	Unit	Conditions
Isolation Voltage	$V_{iso}$	1500	—	—	Vdc	Input to output
MTBF	—	—	$2 \times 10^6$	—	h	BELLCORE TR-332,
Operating Ambient Temperature	—	-40	—	+85	°C	See the derating curve
Storage Temperature	—	-55	—	+125	°C	—
Temperature Coefficient	$S_T$	—	—	$\pm 0.02$	%/°C	—
Relative Humidity	—	10	—	90	%	No condensing, $40^\circ\text{C} \pm 2^\circ\text{C}$
Over Temperature Protection Reference Point	$T_{ref}$	115	120	125	°C	See Over Temperature Protection consideration
Over Temperature Protection Hysteresis	$\Delta T_{ref}$	—	10	—	°C	
Hand Soldering	Maximum soldering Temperature < $425^\circ\text{C}$ , and duration < 5s					
Wave Soldering	Maximum soldering Temperature < $255^\circ\text{C}$ , and duration < 10s					

**Characteristic Curves**

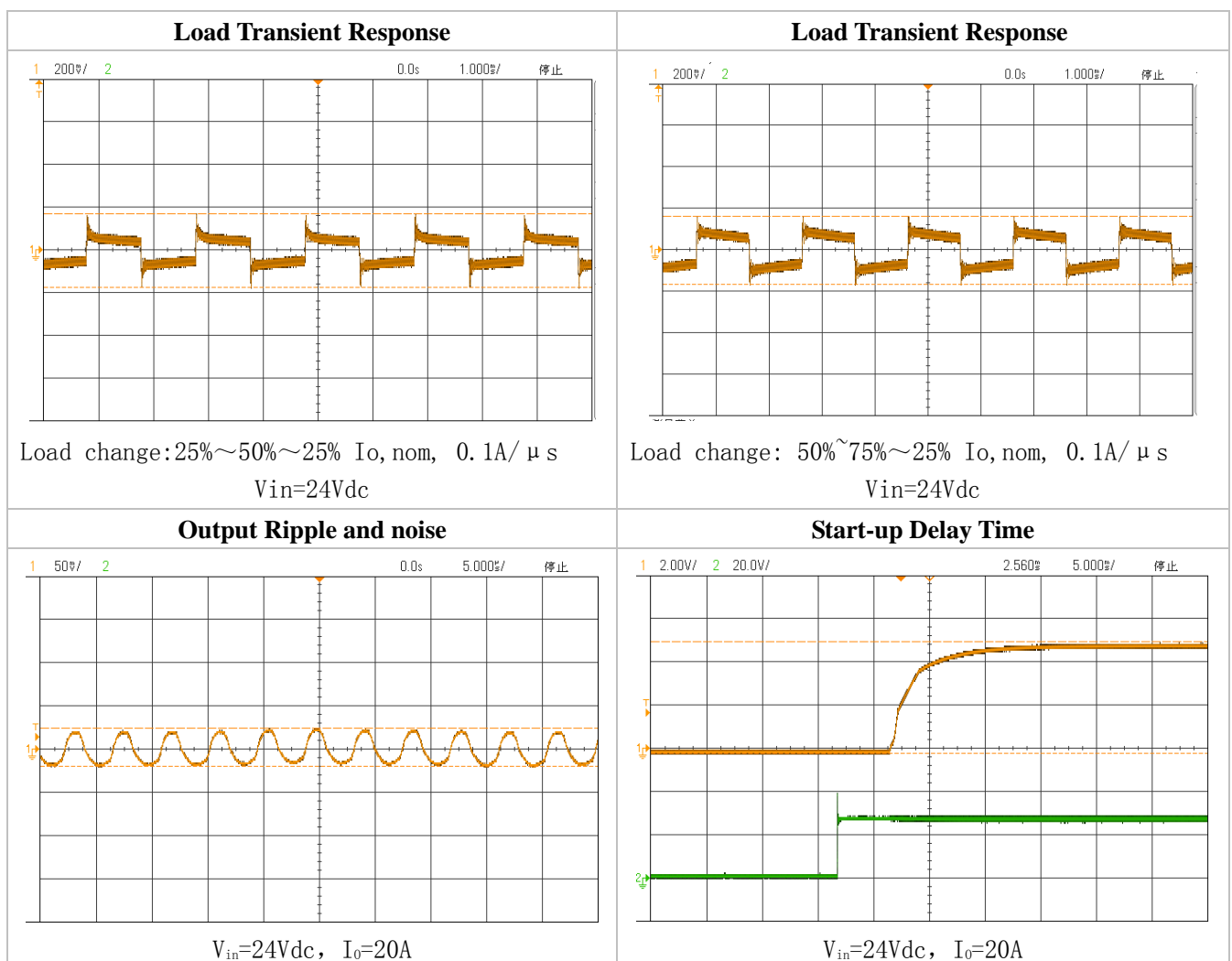

**ZDE20A-24BS5B DC-DC Converters**

Input 9V-36V, Output 5V/20A, Industry Standard Eighth Brick

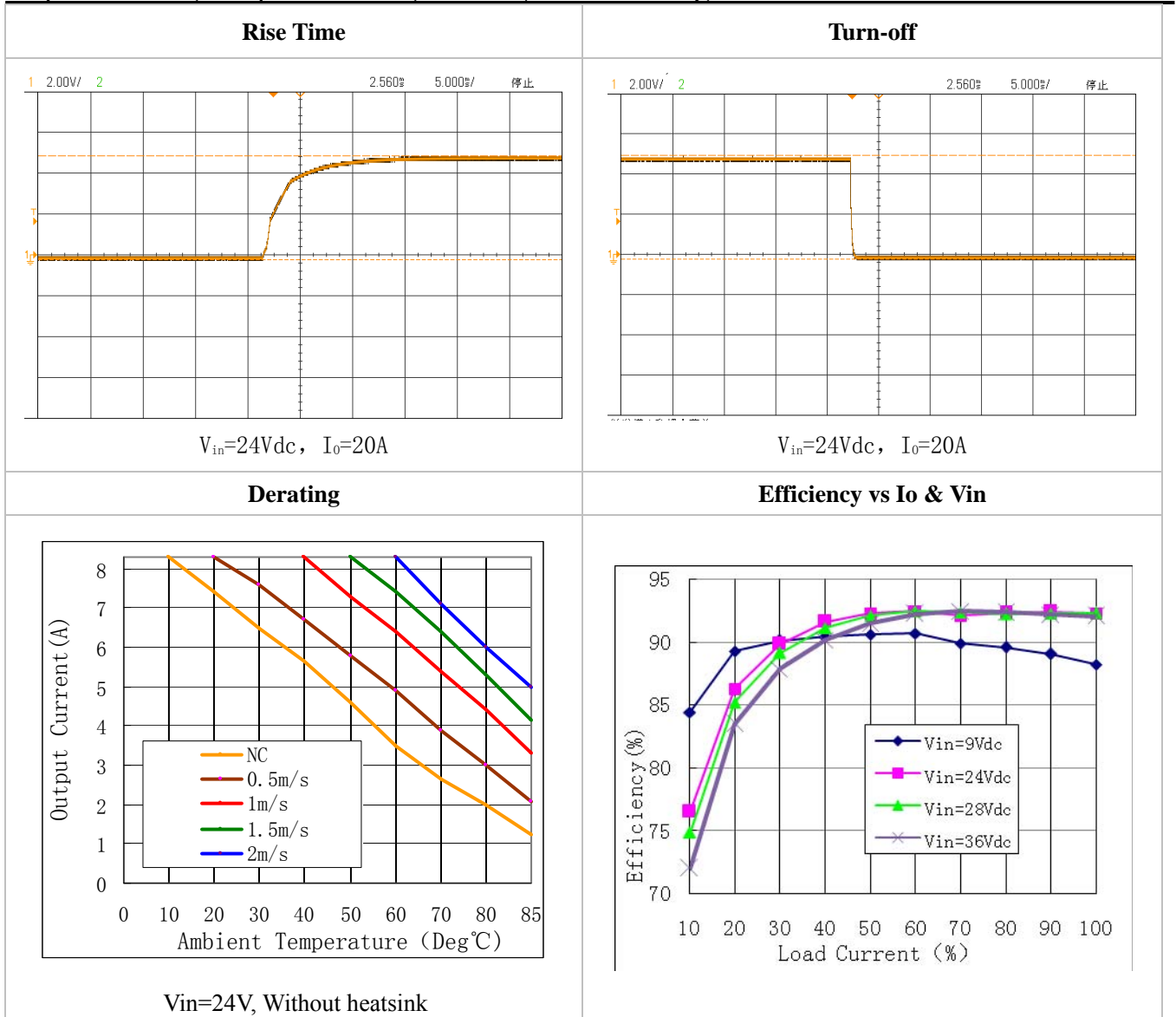

**Design Considerations**

**Basic Connection**

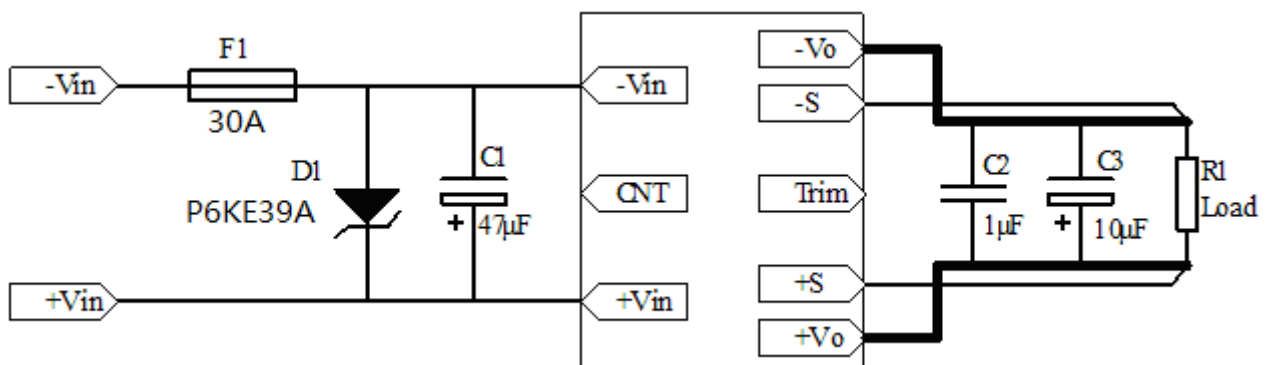

Notes: The basic connection indicates the basic requirements that the power module can provide rated output voltage and rated power only. Please refer the instruction followed for further information.

**ZDE20A-24BS5B DC-DC Converters**

Input 9V-36V, Output 5V/20A, Industry Standard Eighth Brick

**Recommended Layout**

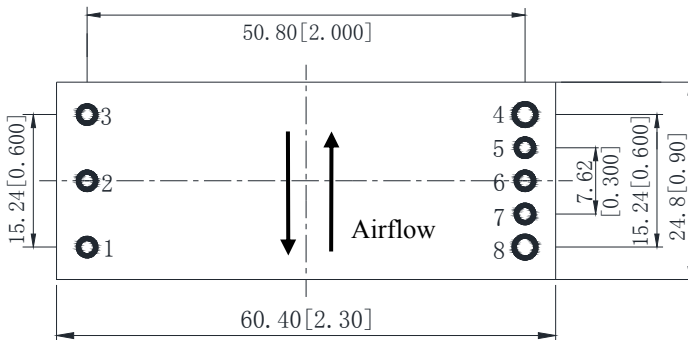

NO.	Recommendation & Notes
Pad Design	Pad hole 4&8: 2.0mm, pad diameter including hole: 3.0mm; the rest are 1.3mm and 2.4 mm respectively.
Airflow Direction	As the figure shown or the opposite direction, perpendicular direction is not recommended.
Safety	Isolated Converters, care to the spacing between input and output
Electrical	The Vin(-) and Vo(-) planes should be placed under of the converter separately. Avoid routing sensitive signal or high disturbance AC signal under the converter.

**Input Voltage Range**

The input voltage range of the DC/DC converter is 9V to 36V。 The input impedance of the converter looks like a negative resistor, which can interact with the reactance of the power bus (including any filter elements that have been added to the input of the converter), causes an unstable condition. Depending on the internal transformer’s impedance, the external impedance usually should not exceed the 10% of the internal. So, the source impedance of the Power bus should be kept as low as possible.

The method to determine whether the impedance of the power bus too high or not is to decrease the converter’s input voltage from higher to lower gradually, if the output voltage decreases (unstable sometime) with the lower input voltage, it will be considered the impedance too large. For further confirmation, one electrolytic capacitor can be paralleled to the converter pins after the converter shuts down (one 1μF ceramic capacitor may be required to be paralleled with the electrolytic capacitor), if the output getting better, it will be sure that the impedance is too large.

**Remote Control**

Remote control can be offered by setting right control voltage level (or floating) to Cnt pin. CDE20A-24BS5 is provided with positive logic remote control. When the level is higher than 3.5V or be left floating, the converter will be turned on. When the level is less than 1.5V, the converter will be turned off. When low voltage level is applied, the output current of the Cnt is less than 5mA. When high voltage level (3.5V~15V) is applied, the input current of the Cnt is less than 5mA

Due to the logic comparator is semiconductor integrated chip, they have low endurance to surge. Care should be taken to prevent Cnt from surge, A TVS should be used in some cases. When the pin is left floating, 2.0V-6.0V voltage appears on the pin.

CDE20A-24BS5P is provided with negative logic remote control. It has the same characteristic as CDE20A-24BS5, except control logic. When the level is higher than 3.5V or be left floating, the converter will be turned off. When the level is less than 1.5V, the converter will be turned on . Like positive logic control converters, care should be taken to prevent Cnt from surge. When the pin is left floating, the voltage of the pin is 2.0V-6.0V.

In some applications, extra controls will be designed for the converter in user’s PCB, such as output short circuit protection, over voltage protection, under voltage protection, and so on, remote control will give you help. The controls can be achieved by external circuit applied to the Cnt pin.

In some applications it is necessary to have a precise turn on and turn off level, or the level which can be received has a very narrow range, the aux. circuit will be required. Please contact us for more information.

**ZDE20A-24BS5B DC-DC Converters**

Input 9V-36V, Output 5V/20A, Industry Standard Eighth Brick

**External Capacitance**

Unless special purpose (i.e. prolonging hold-up time, input impedance matching), the recommended input filter’s capacitance ranges 47μF-220μF, which not only offers a stable system, and reduces the cost, but also lessens the inrush current when the power supplies.

When larger capacitance is required, a circuit of suppressing the inrush current is recommended when the regulator start-up and a discharge circuit is recommended when the output dropped, ensuring the reliability and safety of other equipments in the system.

**Output Voltage Adjust**

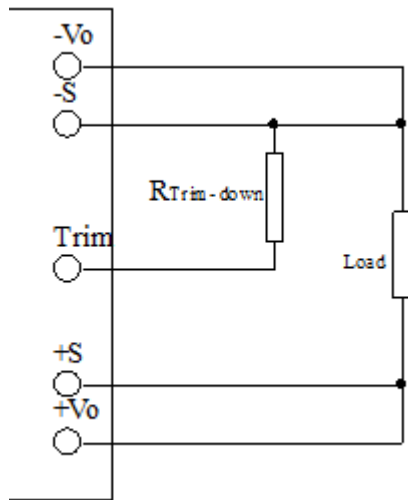

**Connection for Trimming Down**

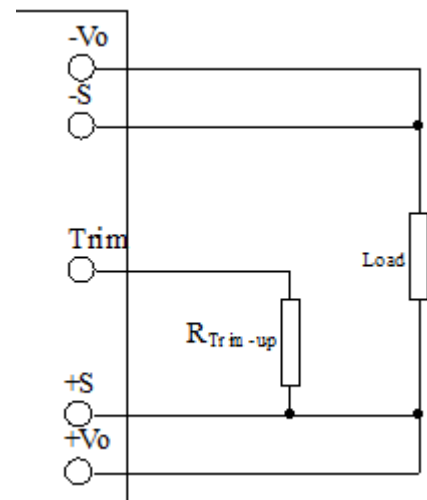

**Connection of Trimming Up**

The converters have an Output Voltage adjust pin (Trim). This pin can be used to adjust the output voltage above or below Output voltage initial setting. When increasing the output voltage, the voltage at the output pins (including any remote sense offset) must be kept below the maximum output adjust range, or the characteristics will not be assured in compliant with the specification, even the over voltage protection may be triggered. Also note that at increased output voltages the maximum power rating of the converter 100W remains the same, and the output current capability will decrease correspondingly, at decrease output voltages the maximum current should not exceed 20A. When the trim pins are not used, they should be floated

External circuit is connected as the figure shown, the resistance is calculated as the formula below, please note that

the formula will be invalid when  $R_{Trim-up}$ 、 $R_{Trim-down}$  are used simultaneously, users adjust the value based on the resistance applied,

$$R_{Trim-up} = \left( \frac{5.11 \times V_o(100(\%) + \Delta(\%))}{1.225 \times \Delta(\%)} - \frac{5.11 \times 100(\%)}{\Delta(\%)} - 10.22 \right) (k\Omega)$$

Resistance for trimming up :

$$R_{Trim-down} = \left( \frac{5.11 \times 100(\%)}{\Delta(\%)} - 10.22 \right) (k\Omega)$$

Resistance for trimming down:

$V_o$ : rated output voltage, 5V;

$R_{Trim-up}$ 、 $R_{Trim-down}$  : Resistance for trimming up or down, kΩ;

**ZDE20A-24BS5B DC-DC Converters**

**Input 9V-36V, Output 5V/20A, Industry Standard Eighth Brick**

$\Delta$  (%): Change rate, divide output voltage by rated output voltage

For example, trimmed down voltage to 4.8V , then  $\Delta$  ( % ) = **【 ( 5-4.8 ) / 5 】** ×100%=4% ;  
 $R_{Trim-down}=5.11 \times 100\% / 4\% - 10.22 = 117.53(k\Omega)$ , it can be taken as 120 k $\Omega$ 。

**Remote Sense**

The remote sense can be used to compensate for the voltage drop between the output pins of the converter and the load input pins by +S、-S pins. The +S and -S pins should be connected to the input pins of the load respectively. The remote sense circuit will compensate for up to 10% voltage drop between the sense voltage and the voltage at the output pins. If the remote sense is not needed, the -S should be connected to -Vout and +S should be connected to +Vout.

The anti-interference design should be considered when the +S、-S pins are connected to the pins to be compensated. The +S、-S traces should be located close to a ground trace or ground plane, and the area they surrounded should be minimized (just for electrical isolation); If cable connection presents, twisted pair wires should be used, EMI core are equipped with the twisted pair wires to reduce common mode noise when necessary, the sense leads should not be longer than 200mm, or the system characteristics may not be assured.

The sense leads only can carry very little current, and are not used for converter power output. Care should be taken in operation to avoid damaging the converter.

**Over Temperature Protection**

The converters provides over temperature protection function. When the PCB temperature (reference point A, see the figure on the right) exceeds the temperature trig point (120 °C) , the OTP circuit will cut down output power. The converter will stop until safe operating temperature is restored. Hysteresis temperature between OTP trig point and restart is approx 10°C. Time between OTP and restart is dependent on cooling of DC/DC converter.

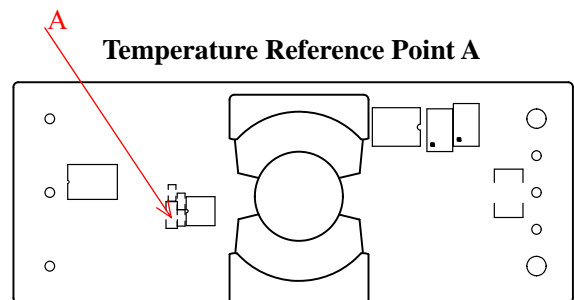

**Thermal Consideration**

The converters operate in a variety of thermal environments; however, sufficient cooling should be provided to ensure reliable operation of the unit. Heat is removed by conduction, convection and radiation to the surrounding environment. For the specified ambient temperature, user can increase airflow and change the size of heatsink to improve the heat dissipating for the module with baseplate; user can only increase airflow to improve the heat dissipating for the models without heat sink. Note that the natural convection condition means that airflow is 0.05~0.1m/s.

**Output Over Voltage Protection**

The converter is designed with clamped over voltage protection, when output voltage exceeds 120% to 140% of the rated output voltage ( the set point is between 120% to 140%, there is the difference based on the specific parameters, but not beyond the range), the output voltage will be clamped. Be advised that to shut down the converter by using remote control if it can not be repaired timely. Avoid the continuous resetting of the unit because that will damage the converter.

**ZDE20A-24BS5B DC-DC Converters****Input 9V-36V, Output 5V/20A, Industry Standard Eighth Brick**

---

**Safety Consideration**

The converter, as a component for the end user, should be installed into the equipment, and all the safety considerations are achieved under certain condition. It is required to meet safety requirements in system design. The converter output is considered SELV, and the expected input is considered TNV2, the primary to secondary is basic insulation to EN60950. The maximum operating temperature for PCB is 170 °C.

To avoid fire and be protected when short circuit occurred, it is recommended that a fast blow fuse with rating 2.5 to 3 times of converter's continuous input peak current is used at the input terminal.

**Series and Parallel Operation**

The converters should not be paralleled directly to increase power, but they can be paralleled each other through o-ring switches or diodes. Make sure that every converter's maximum load current should not exceed the rated current at anytime if they are paralleled without using external current sharing circuits. For the case that there is no external current sharing circuit, but power needs to be increased, please use Trim pin to adjust each converter's output voltage, to load the current as equal as possible in operating (When the load changes in a wide range, the method will not work).

The converters can operate in series. To prevent against start-up failure due to start up time difference, SBD with low voltage difference can be paralleled at the output pins(SBD negative terminal connect to the positive pin of the output) for each converter.

**ESD Control**

The converters are processed and manufactured in an ESD controlled environment and supplied in conductive packaging to prevent ESD damage from occurring before or during shipping. It is essential that they are unpacked and handled using an ESD control procedures. Failure to do so affects the lifetime of the converter.

**Quality Statement**

The converters are manufactured in accordance with GJB 9001B system requirements, and are monitored 100% by auto-testing system, 100% burn in.

The warranty for the converters is 5-year.

**Contact Information**

*Anhui Hesion Trading Co.,Ltd.  
& Beijing WiENpower Technology Co.,Ltd.*

*TEL:+86-551-65369069,65369067*

*Email: [alecz@ahhesion.com](mailto:alecz@ahhesion.com)*

*Backup:[alecz@126.com](mailto:alecz@126.com)*

*[www.ahhesionpower.com](http://www.ahhesionpower.com)*